

SECTION A-A

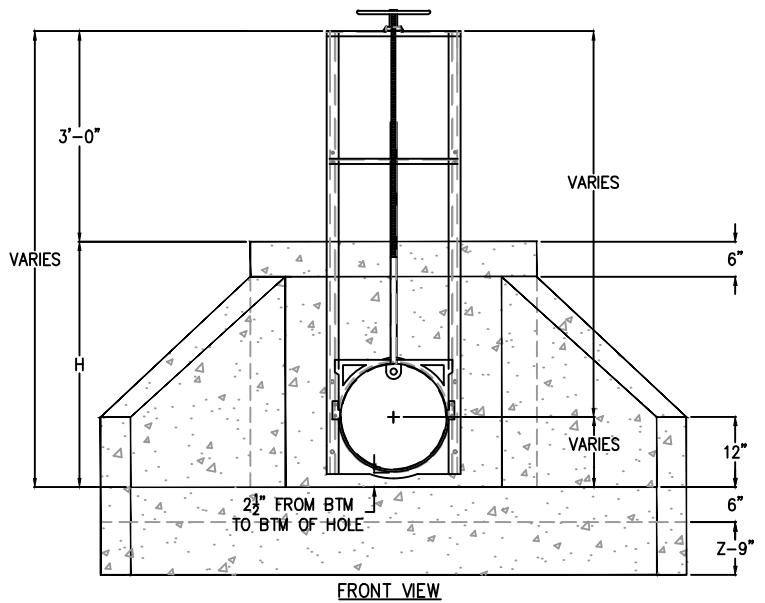

FRONT VIEW

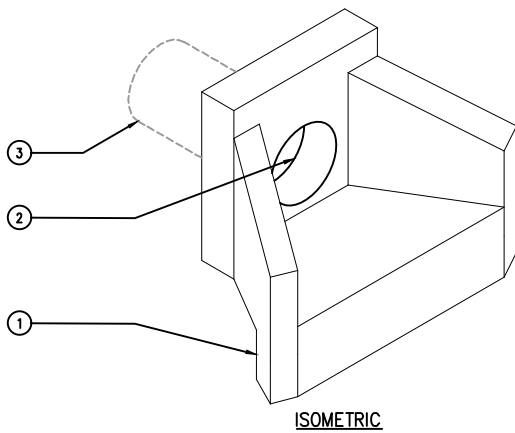

ISOMETRIC

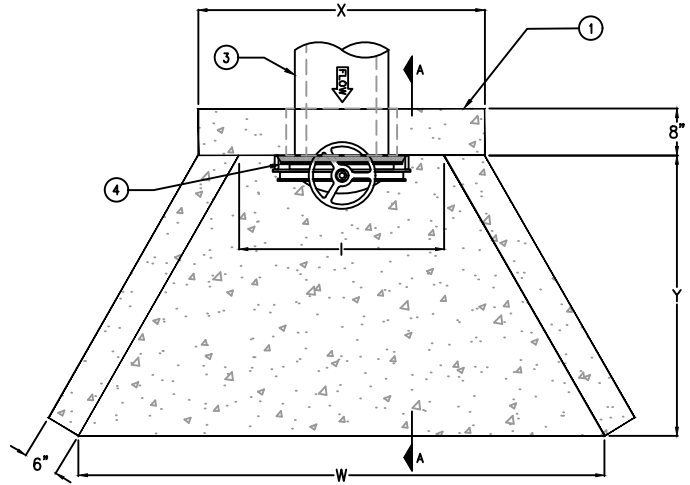

PLAN VIEW

MODEL	PIPE DIA	DIMENSIONS					
		I	H	W	X	Y	Z
SGHW-1218	12"	21"	2'-6"	4'-3"	3'-0"	2'-0"	-
SGHW-1524	15"	24"	3'-0"	5'-10"	3'-2"	3'-0"	-
SGHW-1824	18"	24"	3'-0"	5'-10"	3'-2"	3'-0"	-
SGHW-2136	21"	36"	5'-0"	9'-3"	4'-8"	5'-0"	9"
SGHW-2436	24"	36"	5'-0"	9'-3"	4'-8"	5'-0"	9"
SGHW-3048	30"	48"	5'-3"	12'-9"	5'-10"	7'-0"	12"
SGHW-3648	36"	48"	5'-3"	12'-9"	5'-10"	7'-0"	12"
SGHW-4248	42"	48"	5'-3"	12'-9"	5'-10"	7'-0"	12"

KEYED NOTES		
MARK	QTY	DESCRIPTION
1	1	PRECAST CONCRETE HEADWALL
2	1	BLOCKOUT HOLE FOR PIPE
3	1	STORMWATER PIPE
4	1	CANAL GATE VALVE
5	1	HANDWHEEL



SPECIFICATIONS

CONCRETE: CLASS I/II CONCRETE WITH OF DESIGN STRENGTH OF 4500 PSI AT 28 DAYS. UNIT IS OF MONOLITHIC CONSTRUCTION INCLUDING WALLS AND FLOOR.

REINFORCEMENT: GRADE 60 REINFORCED. NO. 4 STEEL REBAR TO CONFORM TO ASTM A615 ON REQUIRED CENTERS OR EQUAL.

© ParkUSA. ALL RIGHTS RESERVED.



HEADWALL w/ SLIDE GATE VALVE
MODEL SGHW 12" THRU 48"

PM	PC	DRN	ENG	DWG. NO.	REV.
				SGHW-01	A
DATE					

PLOTTED ON 4/19/2024 4:20 PM BY Vu. Kate, C:\Users\vu\Desktop\File replacement website\SGHW-1