

PLAN VIEW

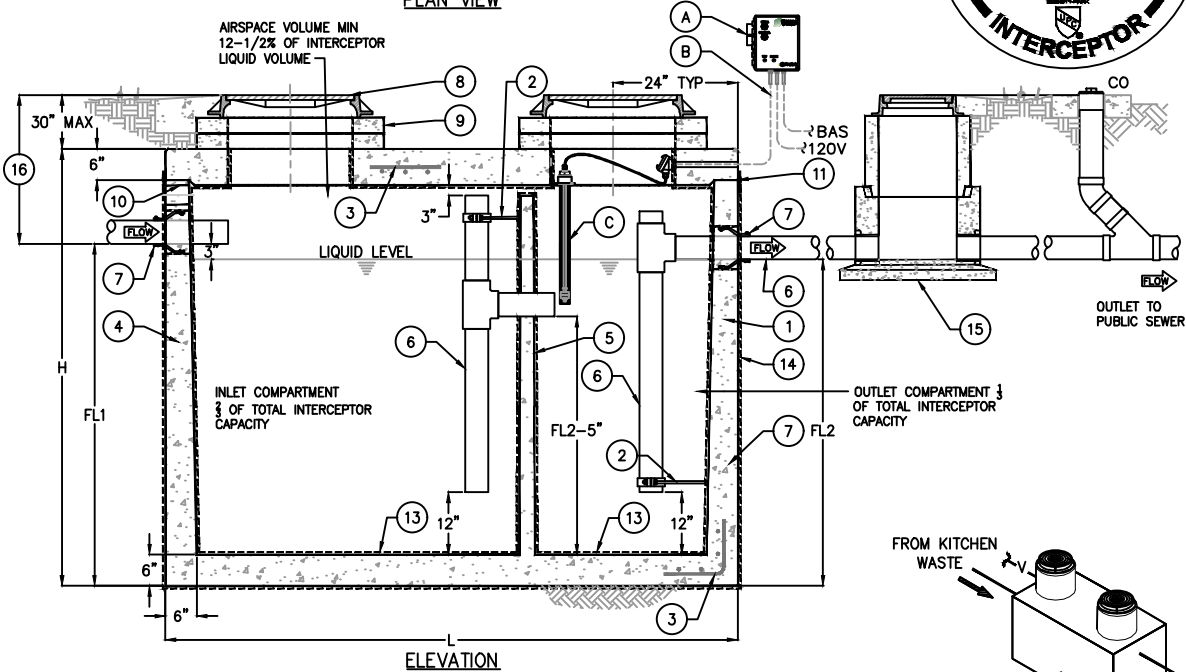

ELEVATION

SERVICE ALERT SYSTEM NOTES		
MARK	QTY	DESCRIPTION
A	1	SERVICE ALERT PANEL, NOTIFIES OF GREASE MAXIMUM CAPACITY w/ AUDIBLE & VISUAL ALARM (NEMA 4X)
B	-	CABLE & CONDUIT ROUTED TO ALARM (BY OTHERS)
C	1	GREASE SENSOR (NEMA 7)

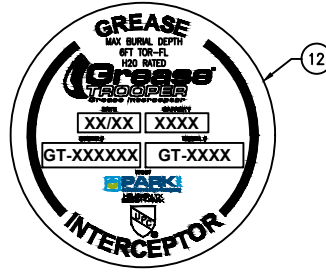

KEYED NOTES		
MARK	QTY	DESCRIPTION
1	1	PRECAST CONCRETE GREASE INTERCEPTOR
2	2	GALVANIZED PIPE SUPPORT
3	-	REBAR AS REQ'D
4	-	TAPERED WALL
5	1	MONOLITHIC BAFFLE
6	2	SCH 40 PVC PIPING (4" OR 6")
7	2	RESILIENT RUBBER CONNECTION
8	2	30" CAST IRON FRAME & COVER (GAS TIGHT)
9	-	CONCRETE EXTENSION RINGS AS REQ'D
10	1	4" VENT TO ABV BUILDING, MIN 1/2 INLET PIPE SIZE
11	1	JOINT SEALED w/ PLASTIC FLEXIBLE GASKET & EXTERNAL WRAP
12	1	NAMEPLATE INDICATING: MFG: ParkUSA.com 888-611-PARK MODEL: GT-UTTD DATE MANUFACTURED
13	1	CHEMICAL-PROOF INTERIOR LINING 3mm HDPE
14	1	BITUMASTIC VAPOR BARRIER ON EXTERIOR
15	-	SAMPLE WELL - PARKUSA SWB-15, 15" DIA X REQ'D DEPTH PRECAST CONTACT W/ 15" MANHOLE FRAME & COVER
16	-	MAXIMUM 6'-0" TOR TO FL

GREASE INTERCEPTOR SCHEDULE

MODEL NO.	CAPACITY USGal	GREASE CAP. (LBS)	EMPTY WT (LBS)	LENGTH L	WIDTH W	HEIGHT H	INLET FL1	OUTLET FL2
GT-1000-UTTD	1,000	2,300	13,200	8'-8"	5'-0"	6'-0"	4'-9"	4'-6"
GT-1200-UTTD	1,200	2,300	13,200	9'-2"	5'-8"	6'-0"	4'-9"	4'-6"
GT-1500-UTTD	1,500	3,500	18,000	9'-0"	6'-0"	7'-0"	5'-9"	5'-6"
GT-2000-UTTD	2,000	4,600	19,000	9'-0"	6'-0"	8'-0"	6'-9"	6'-6"
GT-2500-UTTD	2,500	5,700	27,000	13'-0"	7'-0"	7'-0"	5'-9"	5'-6"
GT-3000-UTTD	3,000	6,900	30,000	13'-0"	7'-0"	8'-0"	6'-9"	6'-6"
GT-3500-UTTD	3,500	8,000	38,500	13'-0"	7'-0"	8'-6"	7'-3"	7'-0"
GT-4000-UTTD	4,000	9,240	38,500	16'-0"	8'-6"	7'-0"	5'-9"	5'-6"
GT-6000-UTTD	6,000	9,240	38,100	16'-0"	8'-6"	9'-0"	7'-9"	7'-6"

OTHER SIZES ARE AVAILABLE. CONTACT US FOR MORE INFORMATION.

© ParkUSA. ALL RIGHTS RESERVED.

GENERAL INFORMATION
 TYPICAL APPLICATIONS INCLUDE COMMERCIAL AND INDUSTRIAL FOOD SERVICE KITCHENS WHERE EXCESSIVE GREASE MAY INTERFERE WITH THE PROPER DRAINAGE OF THE SEWER SYSTEM. THE GREASE INTERCEPTOR IS GENERALLY BURIED BELOW GRADE FOR GRAVITY FLOW SEWER SYSTEMS. A SAMPLE WELL OR CLEANOUT IS UTILIZED ON THE OUTLET SIDE FOR SAMPLING BY THE LOCAL WATER AUTHORITY.

SPECIFICATIONS
 CONCRETE
 DESIGN STRENGTH OF 5000 PSI AT 28 DAYS. UNIT IS OF MONOLITHIC CONSTRUCTION AT FLOOR, FIRST STAGE OF WALL AND BAFFLE WITH SECTIONAL RISER TO REQUIRED DEPTH. (MONOLITHIC BAFFLE REQUIRED, SLIDE-IN TYPE IS NOT ACCEPT)

REINFORCEMENT
 GRADE 60 REINFORCED WITH STEEL REBAR CONFORMING TO ASTM A615 ON REQUIRED CENTERS OR EQUAL.

MANWAYS
 MANHOLE FRAMES, COVERS OR GRATES ARE MANUFACTURED OF GREY CAST IRON CONFORMING TO ASTM A48-76 CLASS 30. MANHOLE SHALL BE NOMINAL 24 INCH DIAMETER AND BE TRAFFIC DUTY.

ENGINEERING DATA
 THE GREASE INTERCEPTOR IS STRUCTURALLY & HYDRAULICALLY ENGINEERED TO CONFORM TO UPC/IPC AND REGIONAL PLUMBING CODES. CONSULT WITH LOCAL AUTHORITIES FOR SPECIFIC APPLICATION REQUIREMENTS.

SHOP DRAWINGS SHALL INCLUDE COMPLETE STRUCTURAL & BUOYANCY CALCULATIONS CERTIFIED BY A LICENSED PROFESSIONAL ENGINEER UPON REQUEST.

CONSULT WITH PARKUSA FOR EXACT EXCAVATION DIMENSIONS & SHIPPING INFORMATION.

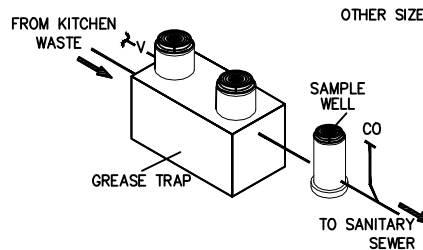

Uniform Plumbing Code Listed

MUNICIPALITIES:

- TIMPANOGOS SPECIAL UTILITY DISTRICT, UT
- LEHI CITY, UT

PARK USA
 A Northwest Pipe Company

GREASE INTERCEPTOR SERIES GT
 1000 THRU 6000 GALLON CAPACITY

PM	PC	DRN	ENG	DWG. NO.	REV.
DATE	5/24	GT-01-UTTD-WA			A

LAST MODIFIED BY KJU ON 5/22/2024 2:42 PM; LAST PLOTTED ON 5/22/2024 2:43 PM BY WJ. KATE; FILE NAME: GT-01-UTTD-WALDING