

PLAN VIEW

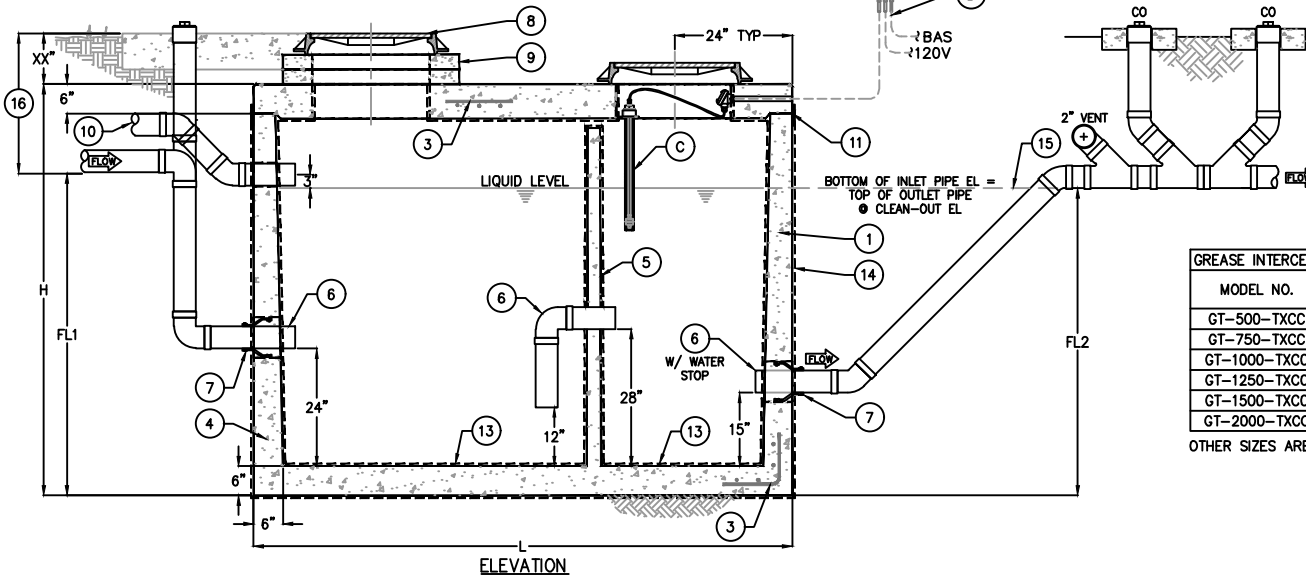

ELEVATION

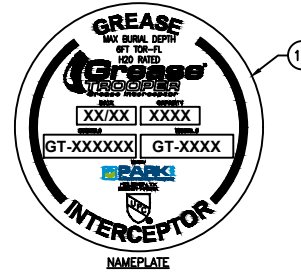

NAMEPLATE

KEYED NOTES		
MARK	QTY	DESCRIPTION
1	1	PRECAST CONCRETE GREASE INTERCEPTOR
2	-	NOT USED
3	-	REBAR AS REQ'D
4	-	TAPERED WALL
5	1	MONOLITHIC BAFFLE
6	3	SCH 40 PVC PIPING (4" OR 6")
7	2	RESILIENT RUBBER CONNECTION
8	2	24" CAST IRON FRAME & COVER
9	-	CONCRETE EXTENSION RINGS AS REQ'D
10	1	4" VENT SLEEVE
11	1	JOINT SEALED w/ PLASTIC FLEXIBLE GASKET & EXTERNAL WRAP
12	1	NAMEPLATE INDICATING: MFG: ParkUSA.com 888-611-PARK MODEL: GT-02-TXCC DATE MANUFACTURED
13	1	CHEMICAL-PROOF INTERIOR LINING 3mm HDPE
14	1	BITUMASTIC VAPOR BARRIER ON EXTERIOR
15	-	INTERCEPTOR WATER LEVEL = INVERT OUTLET PIPE AT CLEANOUT
16	-	MAXIMUM 6'-0" TOR TO FL

GREASE INTERCEPTOR SCHEDULE								
MODEL NO.	CAPACITY USGal	GREASE CAP (LBS)	EMPTY WT (LBS)	LENGTH L	WIDTH W	HEIGHT H	INLET FL1	OUTLET FL2
GT-500-TXCC	500	1,200	7,000	7'-10"	4'-4"	4'-6"	3'-3"	3'-0"
GT-750-TXCC	750	1,700	11,000	7'-10"	4'-4"	6'-0"	4'-5"	4'-2"
GT-1000-TXCC	1,000	2,300	13,200	8'-8"	5'-0"	6'-0"	4'-9"	4'-6"
GT-1250-TXCC	1,250	2,900	15,500	9'-0"	6'-0"	6'-0"	4'-9"	4'-6"
GT-1500-TXCC	1,500	3,500	18,000	9'-0"	6'-0"	7'-0"	5'-9"	5'-6"
GT-2000-TXCC	2,000	4,600	19,000	9'-0"	6'-0"	8'-0"	6'-9"	6'-6"

OTHER SIZES ARE AVAILABLE. CONTACT US FOR MORE INFORMATION.

GENERAL INFORMATION:

TYPICAL APPLICATIONS INCLUDE COMMERCIAL AND INDUSTRIAL FOOD SERVICE KITCHENS WHERE EXCESSIVE GREASE MAY INTERFERE WITH THE PROPER DRAINAGE OF THE SEWER SYSTEM. THE GREASE INTERCEPTOR IS GENERALLY BURIED BELOW GRADE FOR GRAVITY FLOW SEWER SYSTEMS. A SAMPLE WELL OR CLEANOUT IS UTILIZED ON THE OUTLET SIDE FOR SAMPLING BY THE LOCAL WATER AUTHORITY.

SPECIFICATIONS

CONCRETE:
DESIGN STRENGTH OF 4500 PSI AT 28 DAYS. UNIT IS OF MONOLITHIC CONSTRUCTION AT FLOOR, FIRST STAGE OF WALL AND BAFFLE WITH SECTIONAL RISER TO REQUIRED DEPTH. (MONOLITHIC BAFFLE REQUIRED, SLIDE-IN TYPE IS NOT ACCEPTABLE)

REINFORCEMENT:

GRADE 60 REINFORCED WITH STEEL REBAR CONFORMING TO ASTM A615 ON REQUIRED CENTERS OR EQUAL.

MANWAYS:

MANHOLE FRAMES, COVERS OR GRATES ARE MANUFACTURED OF GREY CAST IRON CONFORMING TO ASTM A48-76 CLASS 30. MANHOLE SHALL BE NOMINAL 24 INCH DIAMETER AND BE TRAFFIC DUTY.

SERVICE ALERT SYSTEM NOTES		
MARK	QTY	DESCRIPTION
A	1	SERVICE ALERT PANEL, NOTIFIES OF GREASE MAXIMUM CAPACITY w/ AUDIBLE & VISUAL ALARM (NEMA 4X)
B	-	CABLE & CONDUIT ROUTED TO ALARM (BY OTHERS)
C	1	GREASE SENSOR (NEMA 7)

ENGINEERING DATA

THE GREASE INTERCEPTOR IS STRUCTURALLY & HYDRAULICALLY ENGINEERED TO CONFORM TO UPC/IPC AND REGIONAL PLUMBING CODES. CONSULT WITH LOCAL AUTHORITIES FOR SPECIFIC APPLICATION REQUIREMENTS.

SHOP DRAWINGS SHALL INCLUDE COMPLETE STRUCTURAL & BUOYANCY CALCULATIONS CERTIFIED BY A LICENSED PROFESSIONAL ENGINEER UPON REQUEST.

CONSULT WITH PARKUSA FOR EXACT EXCAVATION DIMENSIONS & SHIPPING INFORMATION.

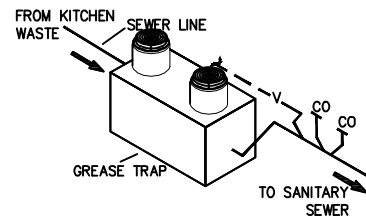

CASPE Member
Uniform Plumbing Code Listed

© ParkUSA. ALL RIGHTS RESERVED.

MUNICIPALITIES:

- CORPUS CHRISTI, TX
- PADRE ISLAND, TX
- ROBSTOWN, TX
- PORT ARANSAS, TX

GREASE INTERCEPTOR SERIES GT
500 THRU 2000 GALLON CAPACITY

PM	PC	DRN	ENG	DWG. NO.	REV.
DATE	5/24			GT-01-TXCC-WA	A

LAST MODIFIED BY KATE ON 5/9/2024 11:32 AM; LAST PLOTTED ON 5/9/2024 11:32 AM; BY KATE; FILE NAME: GT-01-TXCC-WA.DWG