

KEYED NOTES		
MRK	QTY	DESCRIPTION
1	1	TYPE-A 36"x36" INLET BASIN
2	1	36"x36" BOLT DOWN CAST IRON GRATE FOR LARGE DEBRIS
3	1	36"x36" CAST IRON FRAME W/ FPT BOLT THREADS
4	1	REMOVEABLE PERFORATED SOLIDS SCREENING BASKET FOR SMALL DEBRIS
5	-	OIL ABSORBANT MEDIA
6	1	SLOTTED OPENING FOR STORMWATER OUTLET
7	8	OUTLET SECURITY BARS
8	8	STORMWATER OVERFLOW ORIFICE
9	-	CONCRETE ANCHORS (AS REQ'D)
10	2	SCREENING BASKET HANDLES
11	-	GRATE BOLTS (AS REQ'D)
12	1	NAMEPLATE INDICATING: MFG: PARKUSA 888-611-PARK WWW.PARKUSA.COM MODEL: FBRG-36 MFG DATE

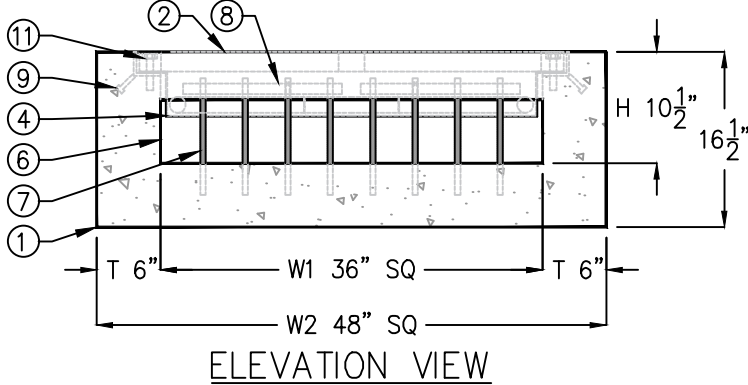

MODEL	W1	W2	H	T	WEIGHT
FBRG-30	30"	42"	10 1/2"	6"	1613 LB
FBRG-36	36"	48"	10 1/2"	6"	2006 LB

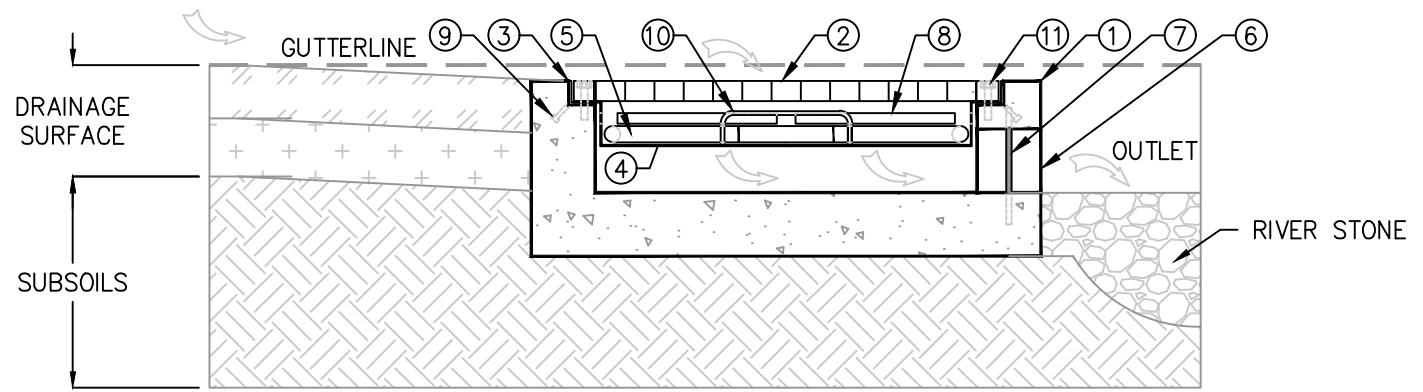

APPLICATION, SECTION A-A

SPECIFICATIONS

- CONCRETE :** CLASS 1 CONCRETE WITH OF DESIGN STRENGTH OF 4500 PSI AT 28 DAYS. UNIT IS OF MONOLITHIC CONSTRUCTION AT FLOOR AND FIRST STAGE OF WALL WITH SECTIONAL RISER TO REQUIRED DEPTH. RATED FOR H-20 LOADING.
- REINFORCEMENT:** GRADE 60 REINFORCED. STEEL REBAR CONFORMING TO ASTM A615 ON REQUIRED CENTERS OR EQUAL.
- C.I. CASTINGS:** CAST IRON FRAMES AND GRATES ARE MANUFACTURED OF GREY CAST IRON CONFORMING TO ASTM A48-76 CLASS 30.

© ParkUSA. ALL RIGHTS RESERVED.



FILTER BASIN – RAIN GARDEN
MODEL FBRG-36

PM	PC	DRN	ENG	DWG. NO.	REV.
DATE	2023			FBRG-1	A

PLOTTED ON 4/22/2024 12:06 PM BY Vu, Kate, D:\File replacement, website\FBRG-1