

PLAN

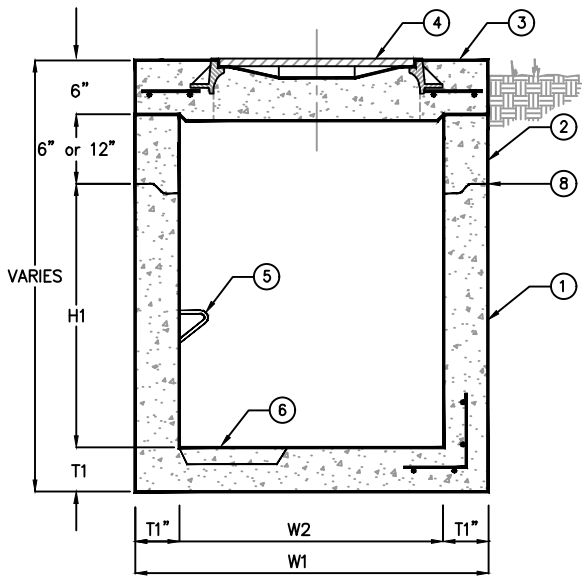

SECTION

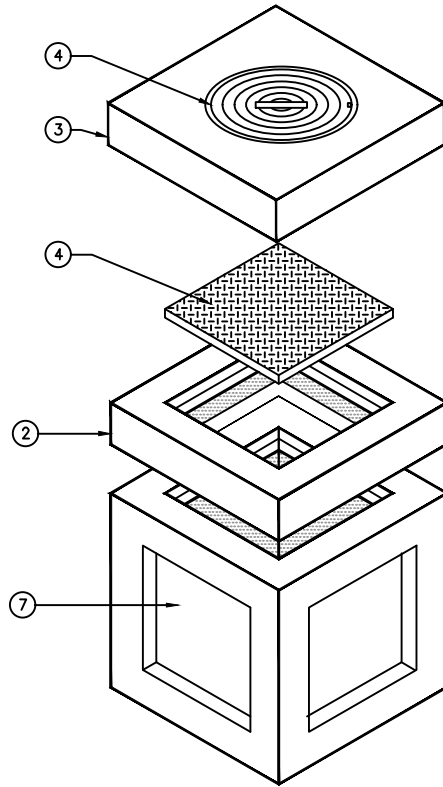

ISOMETRIC

MODEL	W1	W2	H1	T1	STD COVER SIZE	WATERTIGHT COVER SIZE	WEIGHT LBS
ELPB12	15"	10"	21"	2"	12"x12"x1"	N/A	180
ELPB18	24"	16"	30"	4"	18"x18"x1½"	N/A	1,000
ELPB20	26"	18"	36"	4"	20"x20"x1½"	N/A	1,335
ELPB24	32"	22"	48"	5"	24"x24"x2"	N/A	2,245
ELPB27	37"	25"	48"	6"	27"x27"x2"	N/A	2,875
ELPB30	42"	30"	48"	6"	32"x32"x2"	24" DIA	4,100
ELPB36	48"	36"	48"	6"	38"x38"x2"	24" DIA	6,600
ELPB48	60"	48"	48"	6"	38"x38"x2"	24" DIA	9,150
ELPB60	72"	60"	60"	6"	38"x38"x2"	30" DIA	13,650
ELPB72	84"	72"	72"	6"	38"x38"x2"	30" DIA	19,000
ELPB84	96"	84"	72"	6"	38"x38"x2"	30" DIA	23,100
ELPB96	108"	96"	72"	6"	38"x38"x2"	30" DIA	27,500

- 1. CB12 PULLBOX IS RATED FOR PEDESTRIAN LOADING ONLY
- 2. SUMP & GRATE AVAILABLE FOR PB30 THRU PB60 ONLY

KEYED NOTES		
MARK	QTY	DESCRIPTION
1	1	PRECAST CONCRETE ELECTRICAL PULL BOX
2	1	CONCRETE EXTENSION AS REQUIRED
3	1	CONCRETE LID
4	1	COVER, SOLID/MANHOLE
5	1	PULLING IRONS
6	1	RECESSED SUMP w/ CAST IRON GRATE
7	1	THINWALL KNOCKOUTS OR TERMINATORS AS REQUIRED
8	1	JOINTS SEALED WATERTIGHT
9	1	NAMEPLATE MFG: PARKUSA 888-611-PARK WWW.PARKUSA.COM MODEL: ELPB-XX DATE MANUFACTURED S/N: XXXXXX

**SPECIFICATIONS**

- CONCRETE:** Class I/II concrete with of design strength of 4500 PSI at 28 days. Unit is of monolithic construction at floor and first stage of wall with sectional riser to required depth. Rated for H-20 Loading.
- REINFORCEMENT:** Grade 60 reinforced. No. 4 steel rebar to conform to ASTM A615 on required centers or equal.
- C.I. CASTINGS:** Cast iron frames and grates are manufactured of grey cast iron conforming to ASTM A48-76 Class 35.



© ParkUSA. ALL RIGHTS RESERVED.



PRECAST ELECTRIC PULL BOX  
MODEL ELPB

PM	PC	DRN	ENG	DWG. NO.	REV.
				ELPB-1	A
DATE	2023				

PLOTTED ON 4/18/2024 2:35 PM BY Vu. Kate. C:\Users\vu\Desktop\view.pdf\ELPB-1